

Medical Tablet Reference Design



A demonstration of portable, low-power computing for clinicians

The Medical Tablet Reference Design from Emerson Network Power shows the state-of-the-art in high-performance, low-power portable computing for clinicians. It is a demonstration of our ability to support medical equipment OEMs looking to create their own medical tablet. Characterized as 'OEM-ready', the reference design enables customers to draw up their own specification – including branding, industrial design, finish and colors – with technology optimized for their intended applications.

Like the best consumer tablets, the design, which features an Intel® Atom™ processor, is sleek, light and easy to use. It provides a responsive touchscreen interface, sharp graphics on a 10.1" display, configurable wireless networking, support for multiple operating systems and a large 32GB solid-state memory. A powerful battery supports long periods of operation between charges.

But unlike a consumer tablet, the Emerson Network Power design is built with the requirements of the medical industry OEM customers in mind. This starts with the use of an E600 Atom™ processor, one of the Intel family of embedded processors that have a seven-year production life. The same seven-year life applies to the Nano-ITX embedded motherboard from Emerson Network Power that hosts the processor.

Emerson is well-versed in building products for long life applications, so OEMs can be confident that their end product will not suffer from the early obsolescence that is typical of consumer designs.

What's more, this medical reference design shows that Emerson has the capability to create products for the IEC 60601 medical electrical equipment market. And it was created in a world-class Emerson facility with ISO 13485 certification, which represents the requirements for a comprehensive management system for the design and manufacture of medical devices.

Key Features

- 264 mm x 186 mm x 45 mm with handle
- Intel® Atom™ E6xx processor and Intel® EG20T platform controller hub
- 1GB memory
- 3G module; PCI Express Mini Card slot for WiFi/WiMAX connectivity
- PCI Express card expansion slot
- CANbus, serial bus, USB, SPI, and LPC/TPM connectivity
- 200mAh battery providing 3-4 hours of operation from a full charge
- 10.1" LCD display
- 32GB 2.5" SATA solid-state disk
- Fanless cooling
- IP54-rated front panel
- 0-35 °C operating temperature

The reference design shows how a tablet computer can be optimized for use in medical environments. Its robust housing can withstand the knocks and bumps encountered in fast-moving clinical situations, yet at less than 1.5 kilograms (3.3 pounds) in weight, it is light enough to be carried all day. Emerson Network Power has the capability to test products for mechanical shock against a range of specifications.

Emerson Network Power's tablet is also a fanless design to improve reliability & enable silent operation – an important consideration for doctors and patients alike. This design also enables the unit to be sealed, making it easier to clean and disinfect. In addition, the waterproof front panel tolerates frequent applications of sterilizing wipes, and sports an anti-static protective film that helps to repel germs.

A demonstration for today's clinicians

The Emerson Network Power Medical Tablet Reference Design is designed to demonstrate a portable computing architecture for use in clinical environments such as surgeries, operating theatres, emergency rooms, and in field-based applications such as visiting patients in their homes. Use of the latest computing, graphics and communications technology can help clinicians be more productive and provide higher standards of medical care.

Key requirements for a medical tablet include:

- Secure connectivity to clinical systems (such as a hospital's enterprise network) from anywhere, at any time
- Sufficient computing power to run sophisticated diagnostic, data-processing and analysis, communications and other software applications
- High-resolution graphics capability
- Low-power operation to provide long operating times between charges

These capabilities enable hospital doctors, for instance, to access centrally-stored digital patient records at the bedside and update them in real time. A general practitioner on a home visit can view a patient's scans and other images via a secure Internet link to a hospital's network. Clinicians can also search for data about and prescribe medications remotely, giving patients faster and more convenient treatment.

This reference design shows the power of today's technology to support applications such as these. The Emerson Network Power Medical Tablet Reference Design includes:

- The low-power Intel Atom processor offers integrated graphics capability, including dual VGA/LVDS displays, Intel HD Audio & high-speed PCI Express interconnect
- 1GB memory
- 3G module for broadband connectivity
- PCI Express Mini Card slot for a WiFi or WiMAX module
- 10.1" LCD display screen with multi-touch touchscreen and gesture support
- Support for multiple operating systems including Microsoft® Windows®/Windows Embedded, Meego, Android and Linux
- Waterproof (IP54 rating) front panel that tolerates the use of sanitizing wipes

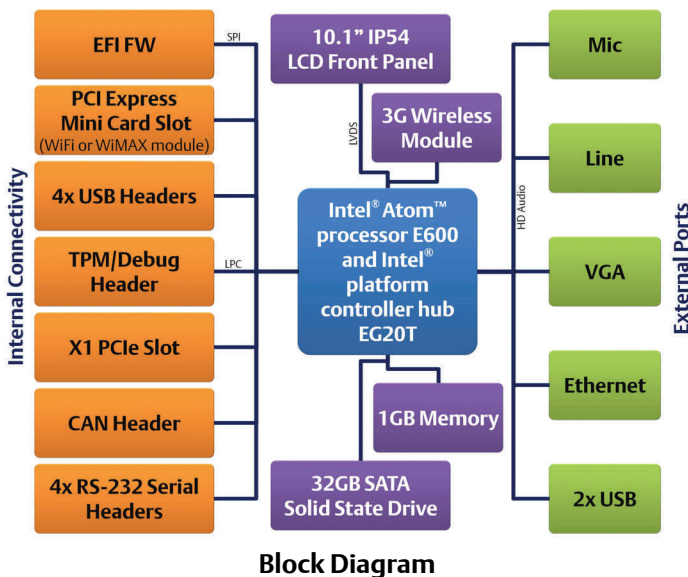

Side view showing connectivity

The Emerson Network Power Medical Tablet Reference Design is available for demonstration. It is fully operational and available with the Microsoft Windows 7 Embedded operating system to enable customers to evaluate its graphics, audio, data processing, communications and other capabilities.

Customers who view the reference design are invited to draw up their own specification, optimized for their intended application(s). Every customer's requirement is different, and Emerson Network Power's design engineering and manufacturing expertise – as demonstrated in this medical tablet – will ensure that each customer receives a product tailored to their needs.

Emerson Network Power can support OEMs by providing:

- Standard embedded motherboards
- Custom embedded motherboards via the RapiDex™ motherboard customization service
- Motherboards with peripherals or additional sub-systems (such as solid-state disks and wireless modules)
- Custom embedded personal computers/tablets

Whatever kind of medical tablet system or sub-system an OEM requires, Emerson Network Power has the design and manufacturing capability to support them.

The Medical Tablet Reference Design is a demonstration of Emerson Network Power's ability to support medical equipment OEMs. It shows expertise in:

- The implementation of low-power computing capabilities in a portable form factor.
- The design of equipment compliant with medical standards. Emerson Network Power has ISO13485 certification for the manufacturing of medical equipment and can supply embedded computing and power products to enable OEMs to meet the IEC-60601-1 medical safety standard.
- The production of mechanical and electrical designs which are suitable for use in clinical environments.

How Clinicians use a Tablet

Patient Records

Clinicians can accumulate vast amounts of health status information on patients with chronic or serious conditions. By storing this information digitally in a central location, medical service providers can provide access to all relevant medical personnel, and update it in real time. Computer technology can help organize and present the data in a way that helps medical personnel interpret it quickly.

Diagnosis

Computer software can help clinicians to understand patterns in symptoms and thus make better and faster diagnoses. This software can be continually updated as new scientific findings produce fresh insights on diagnosis and treatment.

Treatment

Software can be an essential tool for the prescription and administration of medications, especially in complex treatments. Instant access to pharmacopoeias online can also help clinicians to confirm drug choices or search for information on appropriate treatments, side effects, etc.

Further, Emerson Network Power is a part of Emerson Electric Co. (NYSE:EMR), a Fortune 500 corporation with \$21 billion in annual revenues. Emerson is renowned for its engineering and manufacturing excellence. As a large and financially stable corporation, Emerson can give comfort to customers that it will be able to provide service and manufacturing support for the life of their end product.

In the Embedded Computing division of Emerson Network Power, advanced manufacturing facilities wholly owned by Emerson offer customers the advantage of volume support and procurement efficiency.

In addition, the RapiDex™ motherboard customization service provides for faster turnaround times, lower cost and lower volume requirements than any other embedded computing manufacturer can offer.

To arrange to view the Medical Tablet Reference Design, contact your local Emerson Network Power Embedded Computing [sales representative](#) or [distributor](#).

To find out more about the Embedded Computing business of Emerson Network Power, visit www.EmersonNetworkPower.com/EmbeddedComputing.

About Emerson Network Power

Emerson Network Power, a business of Emerson (NYSE:EMR), is the global leader in enabling Business-Critical Continuity™. The company is the trusted source for adaptive and ultra-reliable solutions that enable and protect its customers' business-critical technology infrastructures.

The Embedded Computing business of Emerson Network Power enables original equipment manufacturers and systems integrators to develop better products quickly, cost effectively and with less risk. Emerson is a recognized leading provider of embedded computing solutions ranging from application-ready platforms, embedded computers, enclosures, motherboards, blades and modules to enabling software and professional services.

Manufacturers of equipment for telecommunications, defense, aerospace, medical and industrial automation markets can trust Emerson's proven track record of business stability and technology innovation.

Emerson's engineering and technical support is backed by world-class manufacturing that can significantly reduce time-to-market and help OEMs gain a clear competitive edge. And, as part of Emerson, the Embedded Computing business has strong financial credentials.

Let Emerson help your business improve time-to-market and shift development efforts to the deployment of new, value-add features and services that build market share. With Emerson behind you, anything is possible.

Business-Critical Continuity, Emerson Network Power and the Emerson Network Power logo are trademarks and service marks of Emerson Electric Co. Intel and Intel Atom are registered trademarks of Intel Corporation in the United States and other countries. The Embedded Computing business of Emerson Network Power does not claim medical compliance on its products nor does it offer medical grade products at the time of publishing. All other product or service names are the property of their respective owners. © 2011 Emerson Electric Co.

Emerson Network Power.
The global leader in enabling
Business-Critical Continuity™.

- AC Power
- Connectivity
- DC Power
- Embedded Computing**

- Embedded Power
- Industrial Power
- Infrastructure Management & Monitoring
- Outside Plant

- Power Switching & Controls
- Precision Cooling
- Racks & Integrated Cabinets
- Services