

DC Power  
For Business-Critical Continuity™

NetSure™ ITM  
Row-based, Scalable 48V DC UPS





*Efficiency Without Compromise™*  
provides a path to optimize data center infrastructure around design, operating and management efficiencies – while maintaining or improving availability. This is achieved through the proper selection and utilization of cooling, power and monitoring technologies, supported by key services and local expertise.

## Features & Benefits

- **High system efficiency:** Reduced end-to-end power conversion stages combined with efficient power conversion units (PCUs) and an advanced energy optimization mode enable significant energy savings even at low loads.
- **Scalability and ease of deployment:** Minimize your initial investment and avoid stranded power by adding expansion DC UPS modules without interruption in the field as power needs increase.
- **DC architecture simplicity:** Fewer components, conversion stages and distribution breakers throughout the power chain ensure high availability; elimination of complex synchronization circuits and the need to de-rate capacity for phase balancing or harmonics makes it easy to engineer.
- **High reliability and exceptional resiliency:** Uninterrupted operation in the unlikely event of multiple component failures.
- **Ease of maintenance:** Field replaceable, hot swappable PCUs allow rapid replacement without critical bus disruption; low voltage allows maintenance without bypass or shutdown.
- **Compact footprint:** Row-based, integrated design saves considerable facility space by eliminating the need for a dedicated power room and separate PDU distribution.
- **Flexible deployment options:** Top or bottom cable entry allows for raised or non-raised floor installations.
- **Advanced control and monitoring:** Real time input and output monitoring, including power quality and consumption data, enables facility planning for the system and each branch circuit; state-of-the-art battery monitoring with Albér technology to assure optimal backup performance.
- **One-year warranty:** Provides full system coverage for one year.

## A Complete Power Protection Solution

*The NetSure™ ITM lowers the cost of data center design, operation and management. This 48V direct current solution is a row-based DC UPS that delivers simple, scalable and highly efficient power protection.*

Rising power density, rapid and unpredictable growth, escalating energy consumption and cost, plus a myriad of other power-related challenges are making it increasingly complicated and expensive to protect critical network and computing equipment. The NetSure™ ITM integrates DC UPS components into a compact, highly reliable power protection system, offering the answer to your current and future 48V power needs. This three-phase 480V AC input, 48V DC output UPS provides highly available power to a wide variety of IT applications and delivers advanced operating features combined with reduced total cost of ownership.

The NetSure™ ITM is designed for deployment directly on the server room floor, and provides protected 48V power to nearby equipment racks. This preserves the efficiency and reliability benefits of DC power, while minimizing the amount of copper required and enabling modular growth.



*NetSure™ ITM DC UPS Module  
Top-Cabled Configuration*

*Figure 1: NetSure™ ITM System Efficiency*

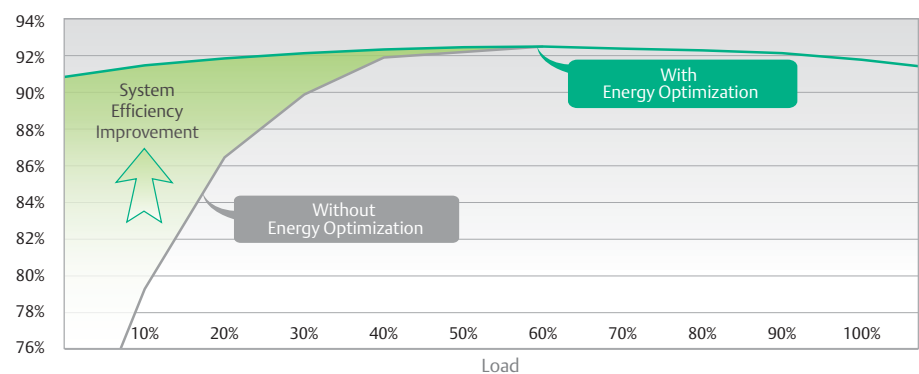



**INFRASTRUCTURE MANAGEMENT**  
Improving performance of the IT infrastructure and environment



**ECO AVAILABILITY**  
Balancing high levels of availability and efficiency



**FLEX CAPACITY**  
Adapting to IT changes for continuous optimization and design flexibility



**HIGH DENSITY**  
Delivering architectures from 10–60 kW/Rack to minimize space and cost

## Unmatched Availability

Central to a data center's strength is its overall uptime. To maintain business continuity, power systems must exhibit high availability and easily scale for increasing capacity.

NetSure™ rectifiers or power conversion units (PCUs) are the heart of the NetSure™ ITM DC UPS. Each DC UPS module includes (12) independent 5.8kW PCUs. These PCUs are globally renowned with over 2 million units deployed, offering unmatched reliability with less than 0.5% return rate (200 years MTBF). The NetSure™ ITM provides many robust features to create a highly redundant package that minimizes common single points of failure.

### Proven power conversion topology

- Each PCU delivers conditioned, isolated power to a common distribution bus
- PCUs function in parallel for seamless redundancy without switching
- Units are hot swappable in the field without system adjustment; minimum field repair time (MTTR) increases overall uptime

### Redundant configuration

- Redundancy can be achieved both within a DC UPS module by PCU (N+x), and by complete system (2N)
- Internal power distribution through (22) branch circuit breakers allows redundant A+B power paths to each rack
- Battery backup via three parallel battery strings
- Optional dual AC inputs allow upstream switchgear maintenance without system outage

### Resilient design

- System bus charges batteries and distributes power directly to the server rack without additional switching or conversions
- 65k AIC withstand rating on AC input breaker(s)
- Controller outage does not interrupt power delivery to the critical load and is field replaceable without system outage

### Battery monitoring technology from Albér

- Detects failing battery cells before they affect the critical load
- Checks each cell and associated connections via a proactive, patented resistance test to reliably predict battery performance
- Provides early warning of cell problems without frequent discharge tests or battery degradation; minimum technician visits with maximum run time protection
- System controller stores raw data accessible via webpage or external monitoring system

## Lower Total Cost of Ownership

DC power is often associated with telecommunications where it has delivered extremely high reliability for decades. Since DC power is both provided by backup power sources and consumed by electronic equipment, a DC power architecture minimizes conversion stages from grid to chip, thus enabling higher overall efficiency with increased availability.

- Factory integrated system for fast and easy site installation
- Service or expansion can be performed while the DC UPS is in operation, reducing maintenance costs
- Compact footprint with built-in batteries and distribution, minimizes required floor space
- Designed for scalable growth to postpone additional capex until capacity is needed
- **Energy Optimization Mode Intelligent Power Matching [Figure 1]**
  - Achieves near-peak UPS efficiency down to 5% system load by optimizing individual PCU performance, greatly reducing energy costs over time in real world conditions
  - Matches delivered power from the UPS to real-time demand, keeping a minimum of PCUs active and putting the rest on standby
  - Balances the run time of each PCU by rotating the active and standby units
  - Maintains the ability to respond quickly to changing load conditions

Whatever the physical layout of your data center, the NetSure™ ITM minimizes required floor space. With DC UPS building block modules, you can mix and match configurations and standard layouts to fit your available space.

## Flexibility to Meet the Needs of Any Data Center

The NetSure™ ITM solution is a modular system in 70 kW increments, expandable up to 280 kW (4 DC UPS modules) with one controller.

### Flexible Capacity

- Each integrated DC UPS module occupies only 24" (W) x 41" (D) of floor space, including batteries and primary distribution
- Delivered fully configured for quick and easy field installation
- Typically installed in either the middle or at the end of a row of server racks
- Deploy only the capacity that is initially needed; DC UPS modules can be added at any time to row configurations on the data center floor
- Choose from top and bottom cabled variants for installation in either concrete or raised floor environments

As Figure 2 illustrates, the NetSure™ ITM solution starts with a primary DC UPS module rated for 70kW. As your power needs increase, you can add up to three expansion DC UPS modules, for a maximum capacity of 280kW that may be configured for N+1 redundancy by subtracting one 6kW PCU from the rating. Each DC UPS module also includes 48V primary power distribution with 22 circuit breakers (6 fuses optional). Various server rack densities are supported with 5-10 minutes of battery backup time across three parallel 48V battery strings.

Figure 3 depicts two top-cable installation scenarios. Depending on your site and budget requirements, the NetSure™ ITM solution can either be installed as a single deployment [Figure 3a], or incrementally by row [Figure 3b] as power requirements grow. In either scenario, DC distribution cabling to each rack is reduced by placing the NetSure™ ITM in-the-row.

Both AC and DC loads can be accommodated at the same site. AC loads can either be protected by an AC UPS or via a rack-mount DC to AC inverter fed from the DC UPS, both available from your local Emerson Network Power representative.

Figure 2: System Scalability

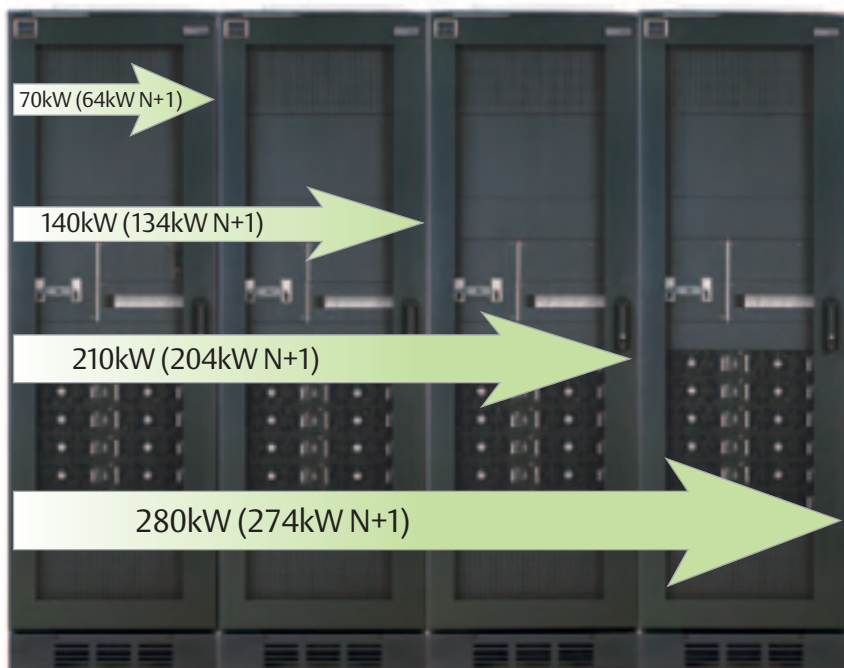

Figure 2: Primary DC UPS module with 3 expansion modules (top-cabled configuration shown) Install only the capacity required; link up to four DC UPS modules to one controller

The NetSure™ ITM easily compliments existing AC power systems, whether you are planning a new facility or expanding an existing data center.

Figure 3: NetSure™ ITM Row-Based Installation Examples

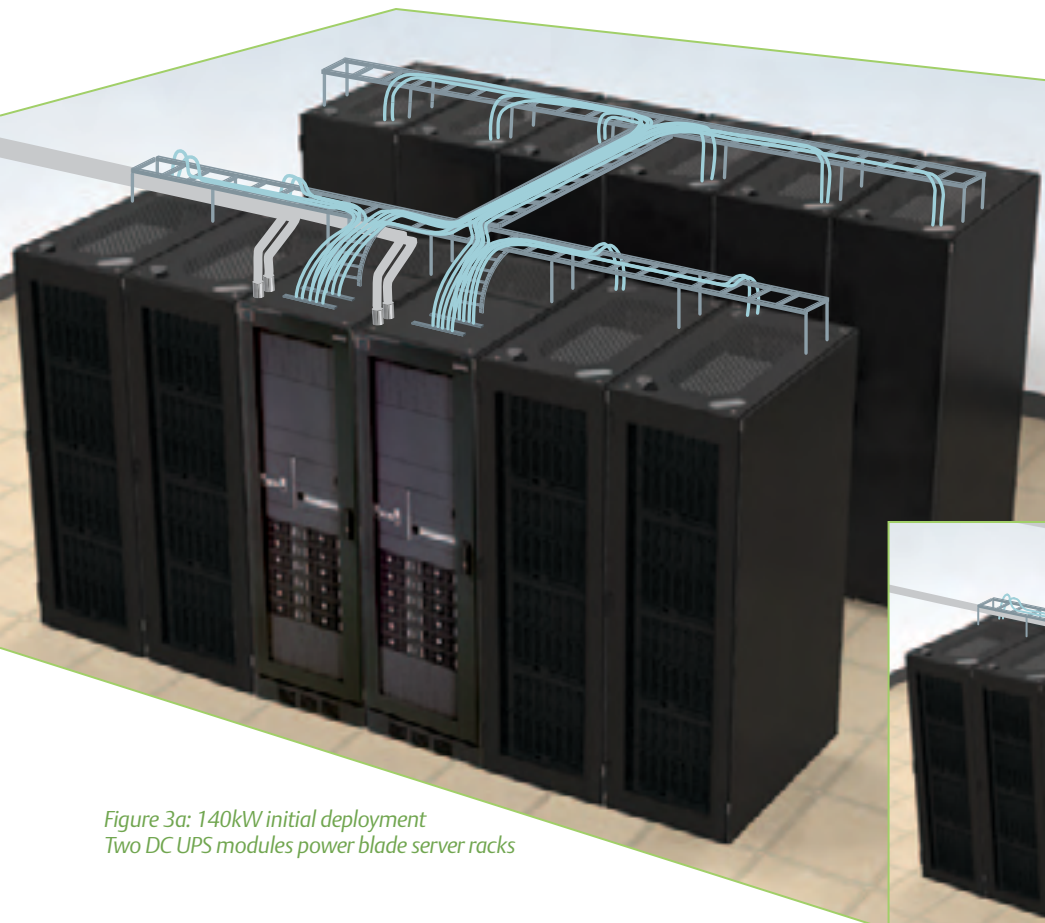

Figure 3a: 140kW initial deployment  
Two DC UPS modules power blade server racks

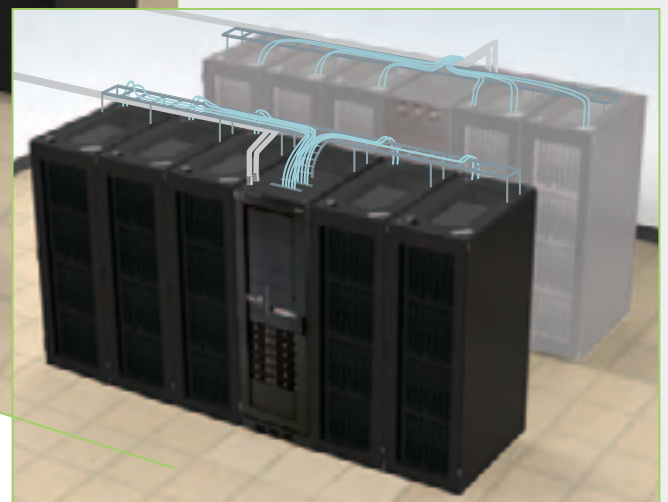
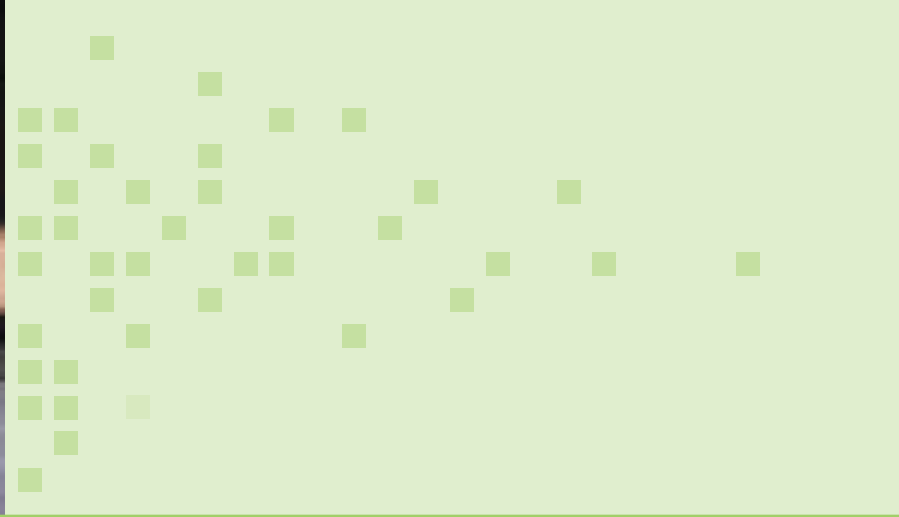

Figure 3b: 70kW initial deployment (front row)  
Add DC UPS and server capacity as needed (back row)

### Ideal Applications for Reliable, Scalable 48V DC Power:

- New and expanding small to medium data centers
- High-density, scalable blade deployments
- Predesigned pods and clusters
- Facilities with constrained power and limited power room space
- Facilities without a dedicated power room
- New deployments with unpredictable growth and limited initial investment
- Applications combining servers and networking equipment (VoIP, PoE, etc.)
- Network testing labs



## Components of the NetSure™ ITM DC Power System

Each NetSure™ ITM DC UPS module consists of twelve 5.8 kW power conversion units (PCUs), an advanced controller, three strings of 6V long-life VRLA battery cells, and 48V DC branch distribution to feed each server rack. In addition to comprehensive efficiency and power metrics, the advanced controller provides complete system and battery monitoring. Furthermore, power to each output circuit is individually monitored. Batteries and your choice of output distribution are integrated into the system prior to shipment from the factory for simplified site installation.



NetSure™ Power Conversion Unit

### Power Conversion Units (PCUs)

Designed for high power density, the foundation of the NetSure™ ITM is the modular, 3-phase input PCU. Installation and maintenance is easy with plug-and-play functionality and a weight of only 17.6 lbs (8 kg). The PCU also features a low THD level (<5%).



NetSure™ System Controller ACU+

### Energy Optimization and Comprehensive Monitoring

All NetSure™ ITM DC UPS modules are controlled and monitored by the Advanced Control Unit (ACU+). Critical system functions and operational conditions as well as alarms can be viewed both locally via LCD display and remotely via a secure web interface, Liebert® SiteScan™ or EnergyMaster™ Remote Supervision. Essential system metrics and alarms are continuously monitored:

- System input and output details
- Battery state of health
- DC output branch distribution circuits



Excellence EB4 VRLA Battery

### VRLA Batteries

The system features three strings of 6V VRLA batteries from Emerson. The Excellence series battery is a top-of-the-line front terminal battery that is designed for reliable and efficient operation with a long life expectancy. High energy density combined with superior endurance ensures long-term, trouble-free performance. Designed for small areas, the Excellence series consumes less rack space and facilitates easy installation and handling. This battery is rated for 10 years at 25°C and includes a 3 year full warranty.



NetSure™ ITM Front View  
(bottom-cabled version shown  
with front covers removed)

NetSure™ ITM Rear View  
(rear cover removed)

- |                                      |   |
|--------------------------------------|---|
| 1 AC input wiring (top or bottom)    | 6 Battery fuses   |
| 2 Power Conversion Unit (12 x 5833W) | 7 48V DC output distribution – 22x100-200A breakers (shown); 2x500A + 4x200A fuses (optional) |
| 3 ACU+ controller                    | 8 Battery cooling fans  |
| 4 480V AC input breaker              | 9 Integrated battery compartment; (3) strings VRLA batteries                                  |
| 5 AC connection point                |   |



SiteWeb™ BRC

### SiteWeb™ BRC with Albér® Technology

Industry leading battery monitoring technology from Albér provides detailed information and alarms regarding the battery backup condition that will minimize site visits and maintenance. The functionality of the SiteWeb™ BRC is integrated with the system controller to continuously monitor and test the battery backup system at the cell or block level without affecting battery performance. It measures cell internal resistance, intercell resistance, cell voltages, battery current and temperature. The information and alarms can be viewed via a web browser or connected to Liebert SiteScan™ or EnergyMaster™ Remote Supervision for long term trending and analysis.

Figure 4: NetSure™ ITM Internal Schematic

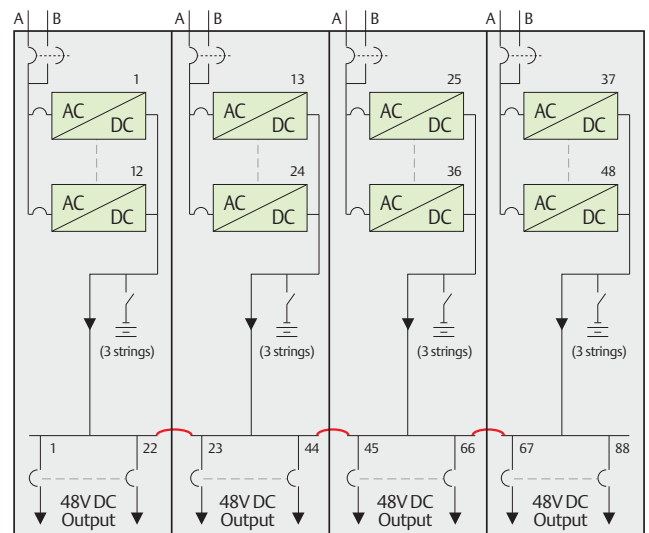

One-line diagram for a four DC UPS module system shown with circuit breaker output and dual AC input.

# Easy Zero Rack Unit Power Distribution

Featuring plug-and-play connectors for simple field connections, NetSure™ RDB 48V Rack Distribution Units are designed to complete your NetSure™ ITM Solution.

## Space Saving Design

When it's time to deploy DC power in your rack, a zero U, rear mount configuration keeps the most rack space available for your revenue generating equipment.

## Robust, tool-less, easy to use

The NetSure™ RDB Series of rack PDUs is designed to handle up to an 8.6 kW load and provisioned to optimize the wire size required to each device. The result is a system that is easy to pre-configure and manage long term.

Because of the plug-and-play connectivity, no special tools or expertise are needed to maintain or move your IT equipment.

- Quick input connectors facilitate easy installation and allow for tool-less field adjustments as layouts or requirements change
- Each outlet is individually protected by a circuit breaker
- Breaker trip notification for added convenience when troubleshooting outages
- Versatile PDU mounting options permit installation in any orientation

## NetSure™ RDB Series Models

### Rack-Mount Server Applications

### Blade Server or High Capacity Switch Applications



NetSure™  
RDB L6

NetSure™  
RDB L15

NetSure™  
RDB M6

**Low Power Distribution**  
(10-20A output breakers)  
6 & 15 outlet configurations

**Medium Power Distribution**  
(25-35A output breakers)  
6 outlet configuration



NetSure™  
RDB H2

NetSure™  
RDB H3

**High Power Distribution**  
(50-80A output breakers)  
2 & 3 outlet configurations

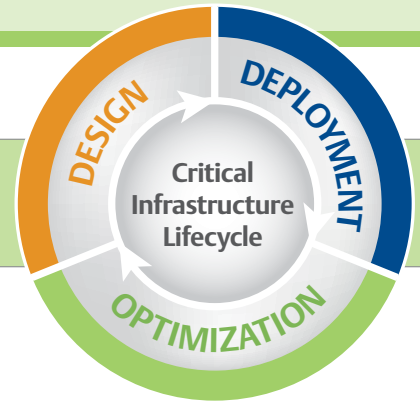

## A Life Cycle of Expert Service and Support

**Trust the service and support of your NetSure™ ITM system to the experts at Emerson Network Power. Our services are offered by technical professionals who have, on average, more than a decade of field experience with DC and network equipment. On the rare occasion that service is required, our technicians can be at your site within hours and are backed by an entire organization ready to help resolve any issues.**

We offer a complete suite of services to optimize and maintain the operation of your NetSure™ ITM solution throughout its life cycle.

### Startup

We know the risks that improper system configuration can pose to your equipment and business. That's why, even if a third-party has installed your system, you can depend on us to perform site testing and verification. We will provide testing and verification of the DC UPS, including PCUs, batteries and control points, to ensure problems are identified before they occur.

### Technical Support

Remote support provides an immediate interface with experienced technical experts 24 hours a day to help resolve unexpected system incidents and support you in operating and managing your DC UPS.

### Preventive Maintenance

Our preventive maintenance programs will ensure your NetSure™ ITM runs at peak system availability and establishes a predictable maintenance budget protected from costly emergency repairs. Periodic inspections identify problems before they occur and maintain maximum operating efficiency. This DC UPS service plan provides a clear picture of system status and recommendations for corrective steps to prevent future problems. Various scopes of work that cover PCUs, batteries (including capacity testing), and DC distribution are available.

Available exclusively to Emerson Network Power preventive maintenance customers, our secure customer website, Freedom-Care, gives you the capability to view and download service and maintenance visit reports.

### EnergyMaster™ Remote Supervision

EnergyMaster™ assessment and remote supervision solutions provide an integrated approach to managing the energy and health of network infrastructures. Emerson experts optimize power consuming equipment for maximum energy savings and provide consistent network reliability through remote supervision routines that reduce maintenance costs.

### Field Service

On-site field engineers are available for scheduled equipment replacement, emergency on-site technical troubleshooting or system field upgrades.

### Training

Courses, offered on-site or in our training center, provide knowledge in the operation, control, troubleshooting and maintenance of the NetSure™ ITM.

### Design and Installation

We offer industry-leading experience and resources to expertly design your DC UPS and 48V DC distribution system. Our field installation team is available throughout North America to provide local knowledge and quick response to project requirements. Installation services offer a variety of options to ensure the project is completed and tested as per agreed upon engineering specifications.



## NetSure™ ITM – Technical Specifications

DC UPS	Primary Module 1	Expansion Module 2	Expansion Module 3	Expansion Module 4
Power Rating (full) – kW	70	70	70	70
Power Rating (N + 1) – kW	64	70	70	70
<b>AC Input Specifications</b>				
Phase	3			
Power Factor	0.99 at full load, 0.98 at 50% load			
Frequency – Hz	45-65			
Input Voltage – Nominal	400 / 480V, 3 wire + ground			
Input Voltage – Range	304-530 VAC; shall withstand up to 600 VAC input without damage.			
Input Breaker Rating / AIC Rating – A	150 / 65,000			
Max Input Current / DC UPS Module	480V: 115A @ 384V; 92A @ 480V			
	400V: 138A @ 320V; 110A @ 400V			
	380V: 145A @ 304V; 116A @ 380V			
Inrush Current	Inrush current does not exceed 150% of the rated input steady state peak value			
Total Harmonic Distortion	<5% from 50-100% of load			
<b>DC Output Specifications</b>				
Voltage	Nominal: -48VDC; normal operation: -54.5 VDC (battery float)			
	Range: -42 to -58 VDC			
System Efficiency	92.5% peak (system level including branch distribution losses)			
Energy Optimization Mode: Intelligent Power Matching	Allows operation at near-peak efficiency down to 5% overall load			
Branch Distribution Options	22 circuit breakers, 100-200A each; optional: 6 fuses, 2x500A + 4x200A			
<b>Battery Specification</b>				
Type	VRLA, Emerson Excellence EB4, 200 Ah			
Arrangement	3 strings; eight 6V blocks per string			
Backup Time	See backup time table at various loads			
Design Life	15 years @ 20 °C ; 10 years @ 25 °C			
Recharge Time (to 97% of nominal capacity)	Less than 3 hours for > 35% load; Less than 4 hours > 15% load			
<b>Physical Data</b>				
Form Factor	Rack			
Installed Dimensions (H x W x D) – in. (mm)	83 x 24 x 41 (2100 x 600 x 1040)			
Installed Weight – lb. (kg)	3214 (1458)			
<b>Environmental Specifications</b>				
System Operating Temp. – °F (°C)	-5 °C to +35 °C; recommended operation with battery: 20 °C to 25 °C air inlet			
System Storage Temp. – °F (°C)	-40 to 158 °F (-40 °C to +70 °C)			
Relative Humidity	0 to 95%, non condensing			
Operating Elevation – ft. (m)	6562 (2000) at full power			
Audible Noise	< 60dB			
Heat Rejection at Full Load – BTU/hr. (kW)	18,096 (5.3) per DC UPS module			
EMI	FCC class A			
<b>Safety Certifications</b>				
Agency Approved	CE Marked to EN 60 950-1:2006			
	UL Listed to 60 950-1 + UL 1801; CSA certified			
<b>Monitoring Capability</b>				
Standard	Web-based monitoring, alarm reporting via SNMP, and integration with SiteScan via SiteLink-E module			
Optional	Energy Master Remote Supervision			

## 5833 Watt PCU – Technical Specifications

DC Output	
Output Power	5833W maximum
Regulation	Steady state output voltage remains within +/-0.25% for any combination of input voltage from 5% to 100% load
Wide Band Noise	Does not exceed 250 mv peak-to-peak, or 100 mv rms per Telcordia GR-947-CORE
Psophometric Noise	Does not exceed 1 mv from 10% to 100% load
Protection	
Current Limiting	The output current is limited to 110 amps
Over Current	Internal fuse
Physical Characteristics	
Mounting	Plug-in installation, hot swappable
Dimensions (H x W x D) – in. (mm)	3.36 x 8.83 x 14.62 (85.5 x 224.5 x 371.5)
Weight – lb. (kg)	17.6 (8)

## Battery Back-up Time (minutes)

DC UPS Load	Single module 70kW	Two modules 140kW	Three modules 210kW	Four modules 280kW
10kW	130	300	480	630
20kW	55	130	210	300
30kW	28	90	130	180
40kW	17	55	90	130
50kW	12	41	70	100
64kW	7	24	50	75
70kW	3	21	43	69
80kW		17	34	55
90kW		14	27	47
100kW		12	22	40
110kW		10	19	34
120kW		8	17	28
134kW		6	16	25
140kW		3	14	22
150kW			12	19
160kW			10	17
170kW			9	15
180kW			8	14
190kW			7	13
204kW			4	11
210kW			2	10
220kW				9
230kW				9
240kW				8
250kW				7
260kW				6
274kW				3
280kW				1

*Peace of mind. It's confidence you've done everything possible to assure system uptime. It's confidence the DC UPS you rely on is operating at peak performance. It's confidence you've selected the best partner available to sustain your critical network infrastructure. **That is Emerson Network Power.***

Emerson (NYSE: EMR), based in St. Louis, is a global leader in bringing technology and engineering together to provide innovative solutions for customers in industrial, commercial, and consumer markets through its network power, process management, industrial automation, climate technologies, and appliance and tools businesses. For more information, visit: [Emerson.com](http://Emerson.com).

Emerson Network Power, a business of Emerson (NYSE:EMR), is the global leader in enabling *Business-Critical Continuity*™ from grid to chip for telecommunication networks, data centers, health care and industrial facilities. Emerson Network Power provides innovative solutions and expertise in areas including AC and DC power, precision cooling, embedded computing and power, integrated racks and enclosures, power switching and controls, infrastructure management, and connectivity. All solutions are supported globally by local Emerson Network Power service technicians. For more information on Emerson Network Power's full suite of solutions specifically supporting the communications network infrastructure, visit: [EmersonNetworkPower.com/EnergySystems](http://EmersonNetworkPower.com/EnergySystems).













Learn more about the NetSure™ ITM DC UPS from Emerson at: [EmersonNetworkPower.com/NetSureITM](http://EmersonNetworkPower.com/NetSureITM).

This publication is issued to provide outline information only which (unless agreed by Emerson Network Power Energy Systems, North America, Inc. in writing) may not be used, applied or reproduced for any purpose or form part of any order or contract or be regarded as a representation relating to the products or services concerned. Emerson Network Power Energy Systems, North America, Inc. reserves the right to alter without notice the specification, design or conditions of supply of any product or service.

Emerson®, Emerson Network Power™, Business-Critical Continuity™, Efficiency Without Compromise™, Albé®®, EnergyMaster™, Liebert®, NetSure™, SiteScan™ and SiteWeb™ are trademarks of Emerson Electric Co. and/or one of its subsidiaries.

**Emerson Network Power**  
**Energy Systems, North America**  
4350 Weaver Parkway, Warrenville, IL 60555  
**Toll Free:** 800-800-1280 (USA and Canada)  
**Telephone:** 440-246-6999 **Fax:** 440-246-4876  
**Web:** [EmersonNetworkPower.com/EnergySystems](http://EmersonNetworkPower.com/EnergySystems)  
**EnergyNet:** [Secure.EmersonNetworkPower.com](http://Secure.EmersonNetworkPower.com)

**Emerson Network Power.**  
The global leader in enabling *Business-Critical Continuity*™.

- |   |  |  |   |
|---|--|--|---|
|  AC Power        |  Embedded Computing                     |  Outside Plant              |  Racks & Integrated Cabinets |
|  Connectivity    |  Embedded Power                         |  Power Switching & Controls |  <b>Services</b>             |
|  <b>DC Power</b> |  Infrastructure Management & Monitoring |  Precision Cooling          |  Surge Protection            |